

OP-LWAN

Universal optical RF module for communication using LoRaWAN technology

The OP-LWAN universal optical RF module is used to record water meter readings and transmit measurement data using the LoRaWAN communication protocol. It enables the detection and registration of events and the transmission of information according to a configurable registration schedule. Assembly takes place directly on water meters manufactured by Apator Powogaz S.A. The device enables a wide range of work schedule configurations. Alarms and historical records sent to the device's memory allow extensive data analysis and diagnostics.



Application

Universal OP-LWAN optical module is intended for installation on single-jet Smart series water meters, manufactured by Apator Powogaz S.A., made according to IP65 protection standards. The device enables cooperation with a wide range of devices creating the structure of remote reading and data transmission. The module is used for water meters with dispersed location architecture and in hard-to-reach locations, such as basements.

Key features

- Cooperation with single-jet water meters of the Smart series, manufactured by Apator Powogaz S.A.
- Can be installed on a water meter in operation
- Immune to external EM fields
- Supports custom configuration of the data transmission interval
- Daily recording of up to 365 events
- Internal antenna
- Battery life - 11 years (depending on configuration)
- IP65 protection rating
- Operating conditions- 0°C ± 55°C

Communication

reading, configuration and recording of data

The OP-LWAN module allows communication for the following purposes:

- Reading the module's current date and time;
- Reading the stored water meter reading
- Reading reverse flow values
- Reading details of alarms and events
- Module configuration
- RTC synchronisation
- Reading the parameters from the module memory

In the basic factory configuration, the following data is sent:

- Current module time,
- Current volume value
- Current reverse volume value,
- Current event flags

Module operation modes:

- Mode 1 - transmit data once a day between 12 am and 12 pm
- Mode 2 - transmit data twice a day from 12 am to 6 am and 12 pm to 6 pm,
- Mode 3 - transmit data three times a day from 12 am to 4 am; 8 am to 12 pm, and 4 pm to 8 pm,
- Mode 4 - transmit data four times a day from 12 am to 3 am; 6 am to 9 am; 12 pm to 3 pm, and 6 pm to 9 pm
- Mode 5 - transmit data six times a day from 12 am to 2 am; 4 am to 6 am; 8 am to 10 am; 12 pm to 2 pm; 4 pm to 6 pm, and 8 pm to 10 pm

Events

The module sends information about the occurrence of an event. The following events/flags can be signalled:

- Clock failure - the current date and time stored in the module is unreliable (NOTE if the 'Clock failure' flag is attached, the module stops storing daily data in the register);
- Device dismantled - no valid data from the reflective pointer. The prolonged presence of this flag may mean that:
 - the module has been removed from the water meter;
 - the reflective indicator of the water meter is damaged;
 - there is contamination between the reflective indicator of the water meter and the optical optocouplers of the module;
- Magnetic field - the module is exposed to a magnetic field (the module must be under the influence of a magnetic field for at least 60 seconds);
- Magnetic field exposure- completed: the module has been exposed to a magnetic field, while no such exposure is currently recorded. In order to determine the start and end time of the magnetic field exposure, it is necessary to read the relevant parameters in the event archive

Regulatory and standard compliance

- compliant with Directive 2014/53/EU of the European Parliament and of the Council of 16 April 2014 on the harmonisation of the laws of the Member States relating to the making available on the market of radio equipment and repealing Directive 1999/5/EC.
- Standards adopted as a basis for compliance assessment: SR-002: ETSI EN 300 220-1 V2.4.1. Electromagnetic compatibility and Radio spectrum Matters (ERM); Short Range Devices (SRD); Radio equipment to be used in the 25 MHz to 1 000 MHz frequency range with power levels ranging up to 500 mW. Part 1: Technical characteristics and test methods.
- SR-003: ETSI EN 300 220-2 V2.4.1. Electromagnetic compatibility and Radio spectrum Matters (ERM); Short Range Devices (SRD); Radio equipment to be used in the 25 MHz to 1 000 MHz frequency range with power levels ranging up to 500 mW. Part 2: Harmonised EN covers essential requirements under article 3.2 of the R&TTE Directive.
- SR-004: ETSI EN 301 489-1 V1.9.2. Electromagnetic compatibility and Radio spectrum Matters (ERM); Electromagnetic compatibility (EMC) standard for radio equipment and services; Part 1: Common technical requirements.
- SR-005: ETSI EN 301 489-3 V1.6.1. Electromagnetic compatibility and Radio Spectrum Matters (ERM); Electromagnetic compatibility (EMC) standard for radio equipment and services; Part 3: Specific conditions for Short-Range Devices (SRD) operating on frequencies between 9 kHz and 246 GHz.
- SR-006: PN-EN 60950-1:2007 PN-EN 60950-1:2007 +A11:2009 +A1:2011 +A12:2011. Information technology equipment — Safety — Part 1.

Specifications

Module	OP-LWAN
Antenna	Internal
Installation method	Directly on the water meter
Installation orientation	Horizontal or vertical
Device operating time	11 years max.*
Performance temperature limits	0°C ÷ 55°C
Ingress protection rating	IP65
Installation requirements	Do not use near strong EM fields or in locations which can severely attenuate the signal
Transmission interval	Depending on configuration - There are 5 operation modes of the module
Protocol	LoRaWAN
Power supply**	Lithium battery, 3.6 V DC AA
Data transmission frequency	EU 868 MHz
Transmitter power output	No more than 25 mW
Outdoor range***	Up to 5 km
Memory	Up to 365 positions
Dimensions	h = 34 mm; s = 65,5 mm
Weight	0.05 kg

* configuration-dependent

** non-replaceable battery

*** depending on environmental conditions, including terrain

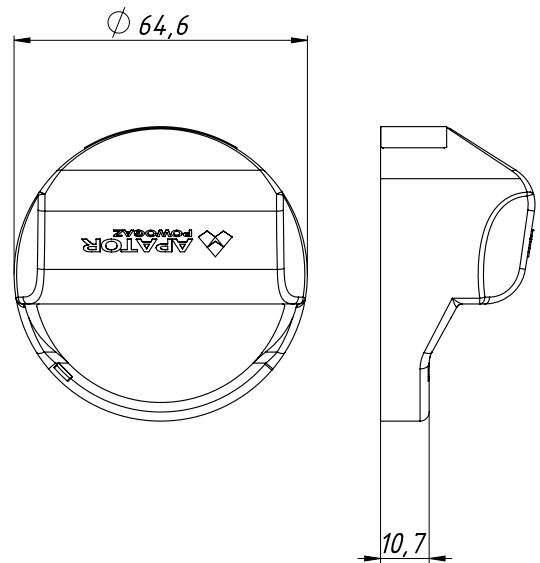
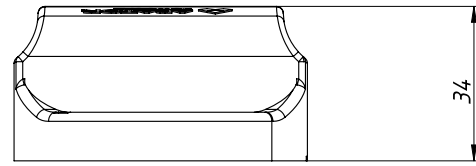

Installation of the OP-LWAN module on the Smart series water meter by Apator Powogaz.



The data shown here is correct on the date of issue.
The manufacturer has the right to modify and improve the products without notice.
This publication is indicative only and should not be construed as a commercial offer under the Polish Civil Code.



Apator Powogaz S.A.

Jaryszki 1c, 62-023 Żerniki

Secretariat: sekretariat.powogaz@apator.com, tel. +48 61 84 18 101

Sales Department / Customer Service: tel. +48 61 84 18 149

Customer Service Center: handel.powogaz@apator.com

Export: export.powogaz@apator.com

Technical support: support.powogaz@apator.com, tel. +48 61 8418 131, 134, 294

Complaints: reklamacje.powogaz@apator.com