

# JS Master D+ IP65/IP68

DN25, DN32 & DN40 single-jet vane-wheel  
water meter

# JS Master D+ IP65/IP68

JS Master D+ is the next generation of the “Master” series of single-jet vane wheel water meters, featuring high measurement dynamics at R200 and a modern design. With the latest design solutions, the metrological performance and durability have been considerably improved, while the immunity to strong magnetic fields remains high. The water meter is compatible with clip-on communication modules for automatic wired or wireless meter reading. The water meter is designed and manufactured in compliance with the MID Directive, pursuant to EN 14154, ISO 4064, and OIML R49, and can be provided with an IP65 or IP68 (for cold water applications only) rating.

## Application

Cold water water supply systems max. 50°C (for IP68 or IP65) in multifamily housing, industrial facilities, public facilities and metering stations. The maximum admissible pressure (MAP) is 16 bar. The water meter is designed for installation in a horizontal orientation with the counter upward (H↑) or sideways (H→), and in a vertical orientation (V). The rotary counter provided indications easily readable directly from the front face and works well in different installation orientations. The standard IP68 version is compatible with universal induction communication modules which feature #UTIP (Universal TI Plug), whereas the IP65 water meters support optical and induction communication modules.

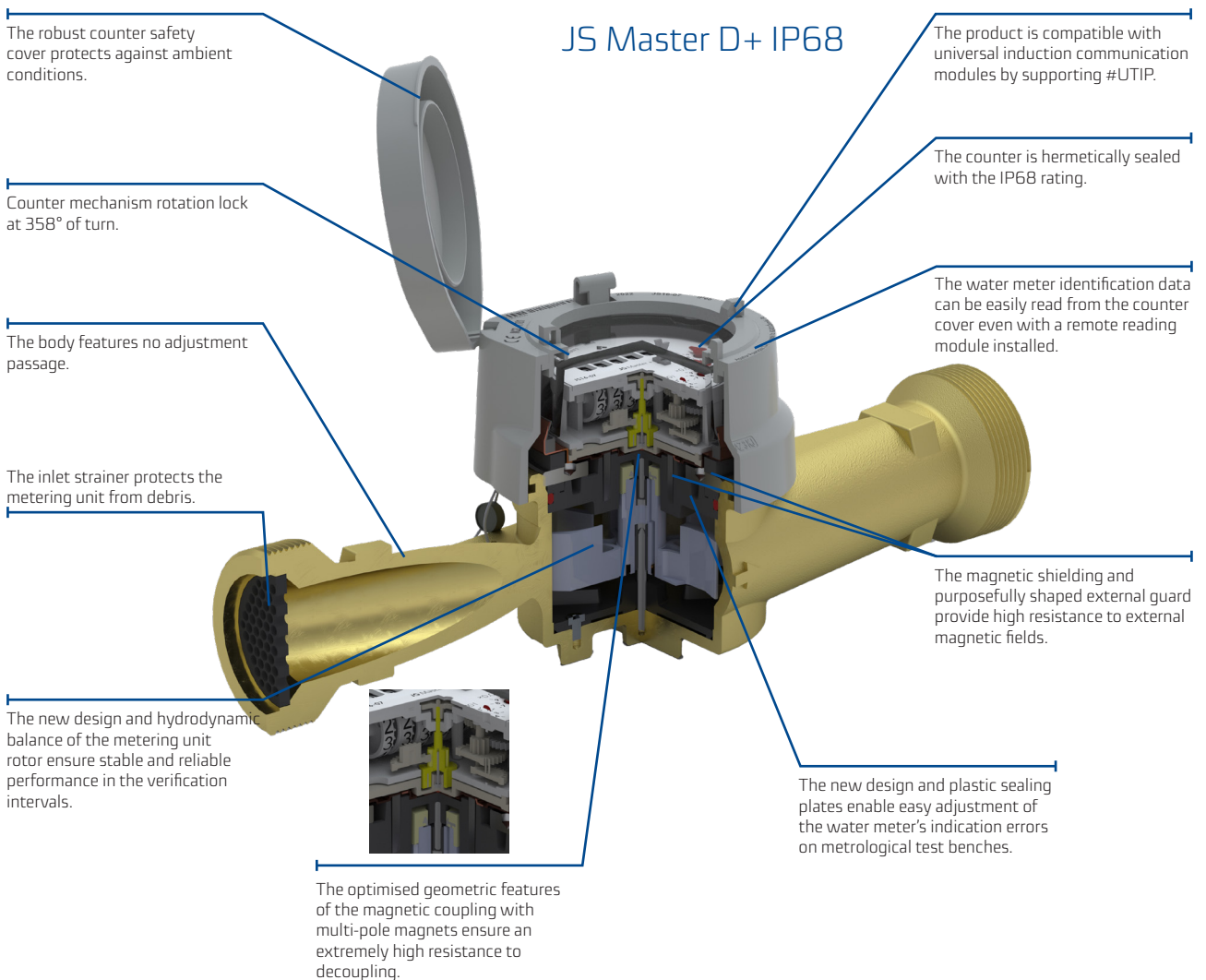

## JS Master D+ IP65

The robust counter safety cover protects against ambient conditions.

Counter mechanism rotation lock at 358° of turn.

The body features no adjustment passage.

The inlet strainer protects the metering unit from debris.

The new design and hydrodynamic balance of the metering unit rotor ensure stable and reliable performance in the verification intervals.

The optimised geometric features of the magnetic coupling with multi-pole magnets ensure an extremely high resistance to decoupling.

The product is compatible with universal induction or optical communication modules.

The counter is hermetically sealed with the IP65 rating.

The water meter identification data can be easily read from the counter cover even with a remote reading module installed.

The magnetic shielding and purposefully shaped external guard provide high resistance to external magnetic fields.

The new design and plastic sealing plates enable easy adjustment of the water meter's indication errors on metrological test benches.

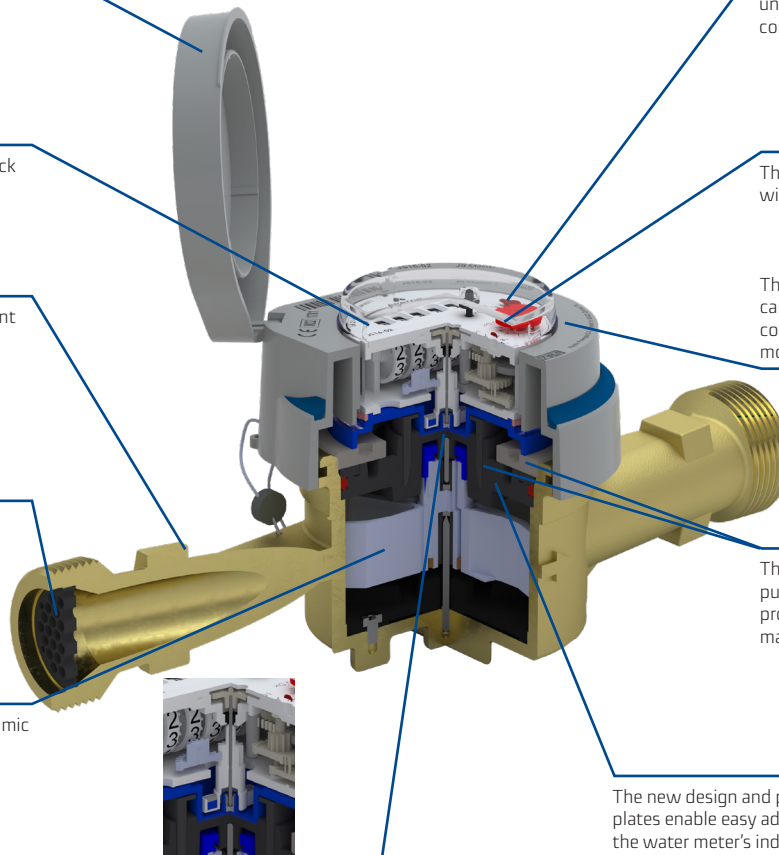

## JS Master D+ IP65 cold water meter version

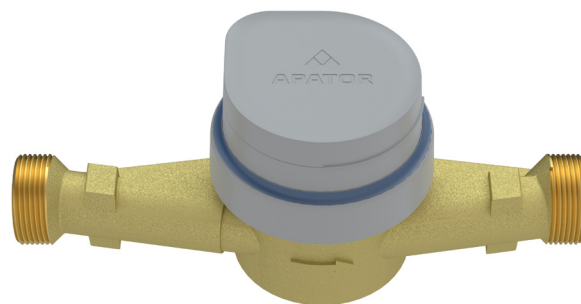

# Advantages

## Economy:

- Precise measurements at R200 – H
- Remote meter reading via wired or wireless interfaces
- Protection against:
  - strong magnetic field effects (by magnetic shielding)
  - mechanical tampering (a robust, tamper-proof counter design)
  - rotation of the counter by more than 358° of turn

## Convenience of use:

- The standard IP68 water meter version is AMR (MDMS)-capable (automatic meter reading) and provided with #UTIP for compatibility with universal induction communication modules
- Easy reading of indications and parameters by:
  - any orientation of the counter mechanism within 0 to 358°
  - hermetically sealed, non-fogging counter in the IP68 version
  - location of the water meter parameter legend on the top edge of the counter cover
- Remote wireless indication reading with a portable terminal or a stationary reading system
- Wired-system based indication reading with:
  - induction communication modules: IN-PULSE (IP65/IP68)
  - optical communication modules: APT-MBUS-NA-2 and AT-MBUS-NE-03 (IP65)
  - NK reed relay pulse transmitter (IP65)
- Wireless-system based indication reading with:
  - induction communication modules: IN-WMBUS, IN-GSM for IP65 and IP68
  - APT-O3A-3 optical communication module (IP65)

## Reliability:

- Tested and robust design
- Long operating life thanks to advanced materials:
  - with high resistance to wearing (in the bearings and pivots)
  - with a surface texture which minimises flow resistance (on the rotor and sealing disc)
  - with a revised construction and the applied hydrodynamically balanced rotor in the measurement chamber
- The inlet strainer (which protects the metering unit from debris)
- The counter mechanism is protected against mechanical damage
- The snap-locked counter cover features the verification marking to eliminate traditional tamper seals

## Key features

- Output of event alarms: when equipped with an RF module, the water meter can indicate removal or breaking off of the module, module operating interruptions, reverse flow, leaks, etc.
- The applied structural and material solutions in the R200-rated measurement unit improve the performance and reliability, ensuring stable metrological parameters in the entire service life
- Highly aesthetic water drop-shaped design of the counter safety guards and covers
- The inlet passage design stabilises the flow in the entire verification period
- Ultra-light, hydrodynamically balanced rotor on two-point bearings
- IP68 rating: the water meter is capable of operation in extremely difficult ambient conditions (and also when fully immersed in water), also with an induction communication module installed

## New design of the cover and the face, exemplified by the IP65 counter

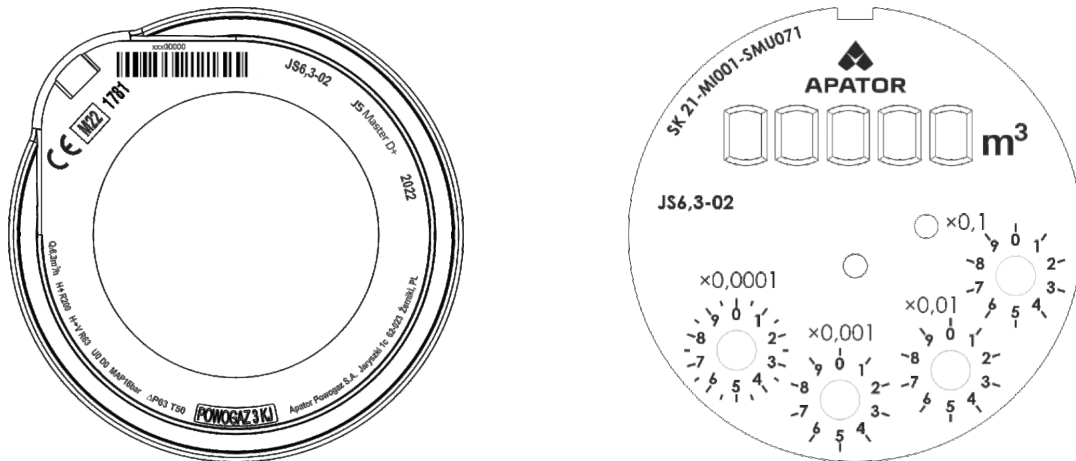

## Regulatory and standard compliance

- Directive 2014/32/EC of the European Parliament and of the Council of 26 February 2014 on the harmonisation of the laws of the Member States relating to the making available on the market of measuring instruments
- OIML R 49-1:2006 – Water meters intended for the metering of cold potable water and hot water. Part 1: Metrological and technical requirements
- OIML R 49-2:2013 – Water meters intended for the metering of cold potable water and hot water. Part 2: Test methods
- OIML R 49-3:2013 – Water meters intended for the metering of cold potable water and hot water. Part 3: Test report format
- EN 14154-1:2005+A2:2011 – Water meters. Part 1: General requirements
- EN 14154-2:2005+A2:2011 – Water meters. Part 2: Installation and conditions of use
- EN 14154-3:2005+A2:2011 – Water meters. Part 3: Test methods and equipment
- EN ISO 4064-1:2017 – Water meters for cold potable water and hot water. Part 1: Metrological and technical requirements
- EN ISO 4064-2:2017 – Water meters for cold potable water and hot water. Part 2: Test methods
- EN ISO 4064-5:2017 – Water meters for cold potable water and hot water. Part 5: Installation requirements
- EC type examination certificate no. SK 21-MI001-SMU071
- Classification of environmental climate and mechanical conditions: Class B (ref. PN-ISO 4064-1:2014 (E))
- Classification of mechanical environment conditions: Class M1 (ref. Polish Regulation Dz.U. 2006.12.18)
- Classification of electromagnetic environment conditions: Class E1 (ref. Polish Regulation Dz.U. 2006.12.18)

All materials of the JS Master+ IP65/IP68 water meters have PZH-NIH Hygiene Certificates for use with potable water.

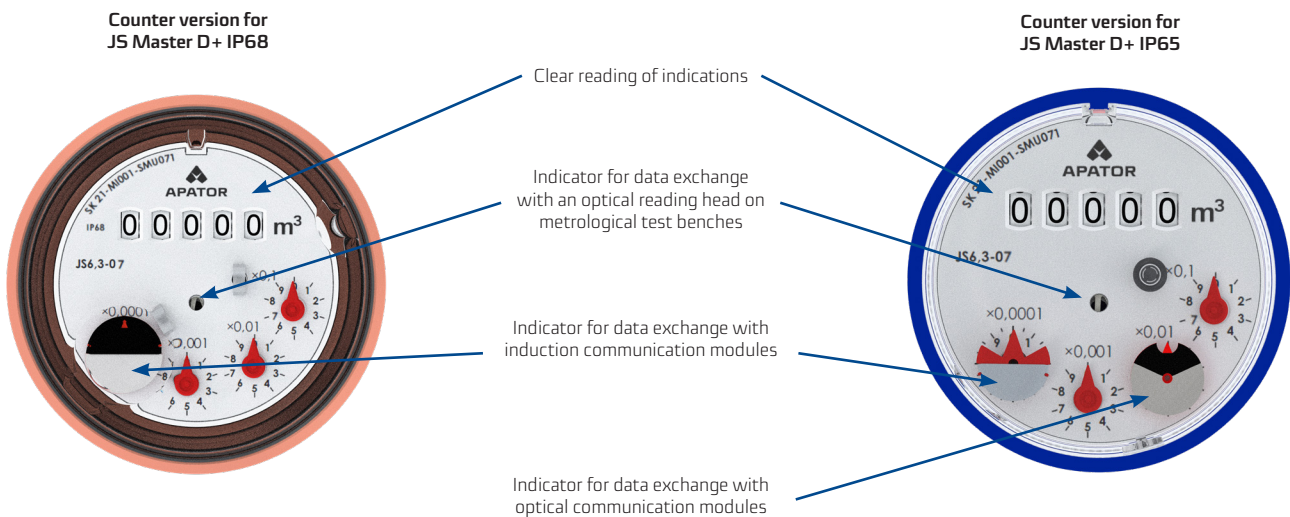

Table 1. Specifications

Parameter			JS Master D+ IP65/IP68				
	For cold water		JS6,3-02* JS6,3-06-NK** JS6,3-07***	JS10-G1¼-02*, JS10-02*, JS10-G1¼-06-NK**, JS10-06-NK**, JS10-G1¼-07***, JS10-07***	JS16-02* JS16-06-NK** JS16-07***		
Nominal diameter	DN	mm	25	25	32	40	
Permanent flow rate	Q <sub>3</sub>	m <sup>3</sup> /h	6.3	10		16	
Maximum flow rate	Q <sub>4</sub>	m <sup>3</sup> /h	7,875	12,5		20	
Transitional flow rate	cold water	H↑ R200 V, H→R63	Q <sub>2</sub>	dm <sup>3</sup> /h	50 160	80 254	128 406
Minimum flow rate	cold water	H↑ R200 V, H→R63	Q <sub>1</sub>	dm <sup>3</sup> /h	32 100	50 159	80 254
Starting flow	cold water		–	dm <sup>3</sup> /h	10	18	24
Q <sub>2</sub> /Q <sub>1</sub> ratio	–	–	1.6				
Temperature class (rated operating temperature)	–	–	T30, T50				
Flow profile sensitivity class	–	–	U0, D0				
Indicating range	–	m <sup>3</sup>	99,999				
Resolution of reading	–	m <sup>3</sup>	0.00005				
Maximum pressure	P <sub>max</sub>	MPa	1.6				
Maximum pressure loss	Δp	kPa	63				
Maximum permissible error range: Q <sub>2</sub> ≤ Q ≤ Q <sub>4</sub>	ε	%	±2 for 0.1 to 30°C cold water ±3 for >30°C water				
Maximum permissible error range: Q <sub>1</sub> ≤ Q < Q <sub>2</sub>	ε	%	±5				
Reed relay pulse transmitter NK	–	dm <sup>3</sup> /h	10 (standard pulsing)			100 (standard pulsing); 10	
Inlet and outlet pipe end threads	G	Inch	G1¼	G1¼	G1½	G2	
Dimensions	h	mm	36 (07); 36.1(02; 06)				
	H	mm	115 (07); 110 (02); 128.6 (06)				
	H1	mm	123 (07); 114 (02)				
	H2	mm	200 (07); 191 (02)				
Length	L	mm	165***/260	260		300	
	l	mm	285***/380	380		440	
Diameter	D	mm	111				
Weight (w/o connection fittings)	–	kg	2.0	2.2		2.5	

\* Version 02 – IP65-rated counter mechanism and cover; the water meter supports readout with induction communication modules (Ti) and optical communication modules (IR)

\*\* Version 06 – IP65-rated counter mechanism with the reed relay pulse transmitter (NK)

\*\*\* Version 07 – IP68-rated counter mechanism and cover; the water meter supports readout with induction communication modules (Ti)

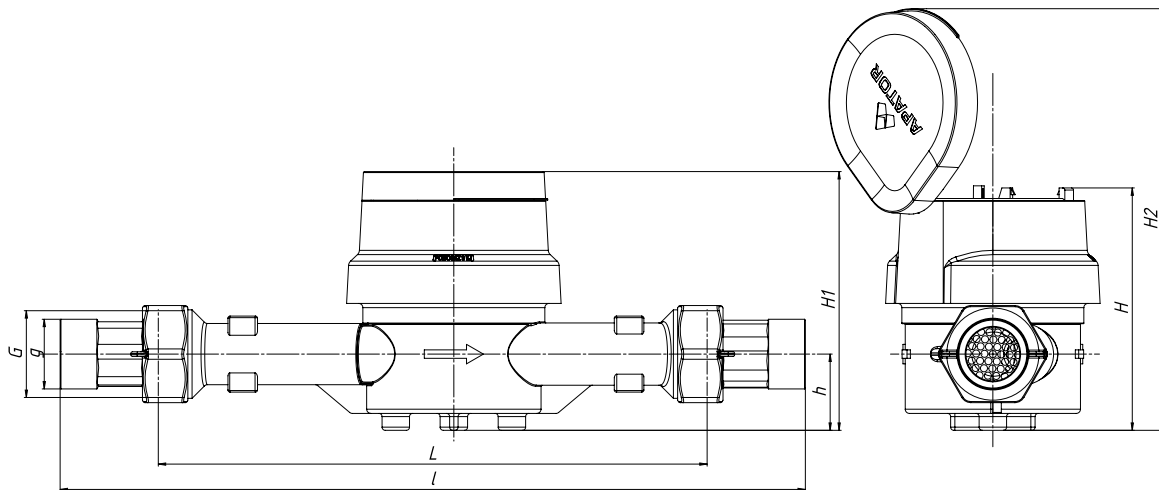

Figure: JS Master D+ version -07 (IP68)

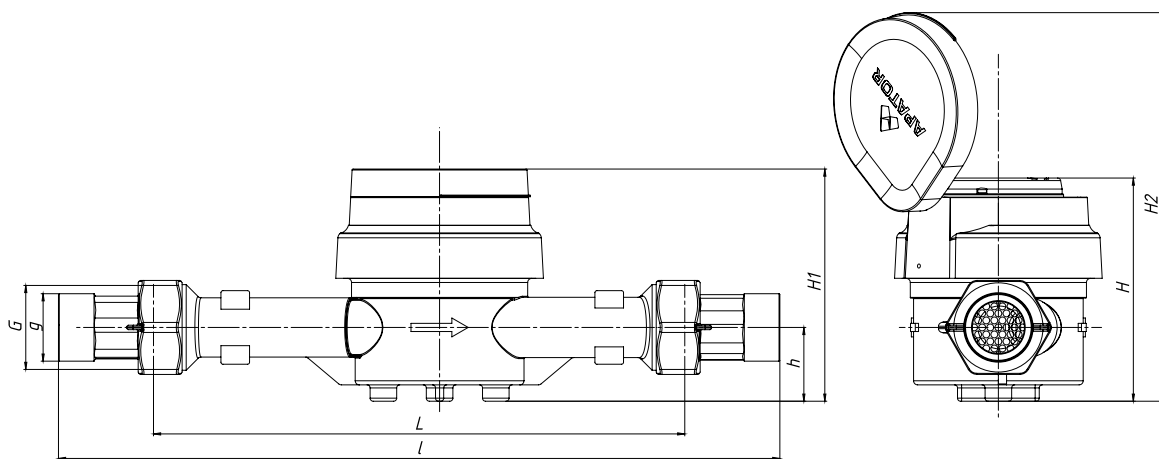

Figure: JS Master D+ version -02 (IP65)

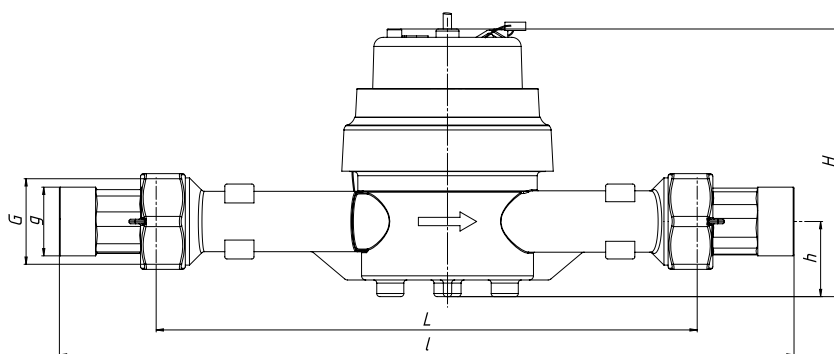
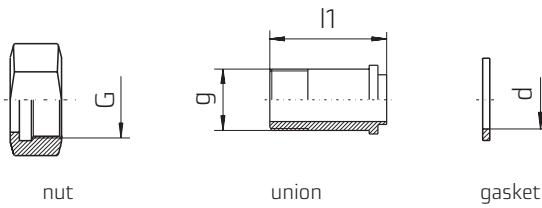

Figure: JS Master D+ version -06 (IP65)

## Connection fittings



DN	G	g	d	l1
25	1¼"	1"	29	46.5
32	1½"	1¼"	36	56
40	2"	1½"	43	66

Example of the JS Master+ IP68 version -07 water meters with compatible data communication modules:

**IN-GSM** clip-on module, #UTIP (Universal TI Plug)

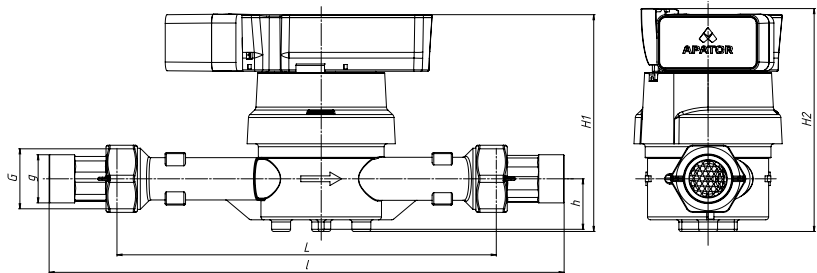
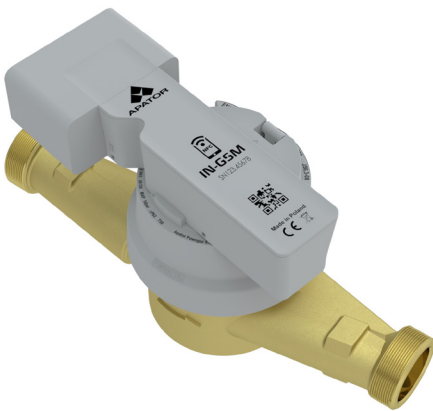

DN	25	25/32	40
H1	mm	149	
H2	mm	153	

**IN-WMBUS** clip-on module, #UTIP (Universal TI Plug)

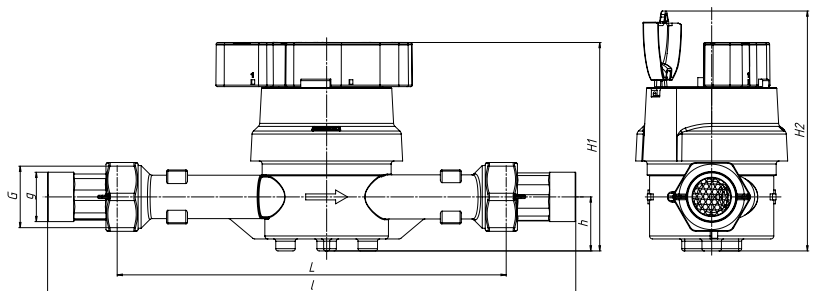

DN	25	25/32	40
H1	mm	140	
H2	mm	160.5	



Example of the JS Master+ IP65 version -02 water meters with compatible data communication modules and version -06 with the NK module:

**IN-GSM clip-on module with the interface ring**

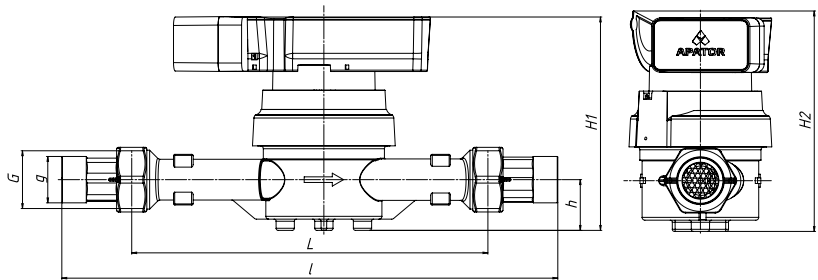
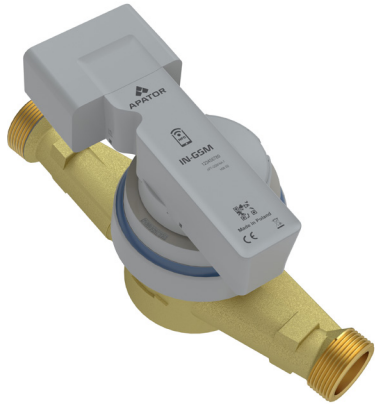

DN	25	25/32	40
H1	mm	151.85	
H2	mm	156.84	

**IN-WMBUS & IN-PULSE clip-on modules with the interface ring**

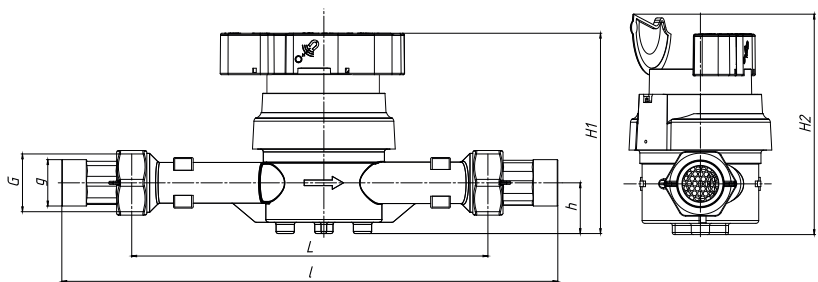

DN	25	25/32	40
H1	mm	142.55	
H2	mm	156.84	

**IP65-rated water meter with the NK module**

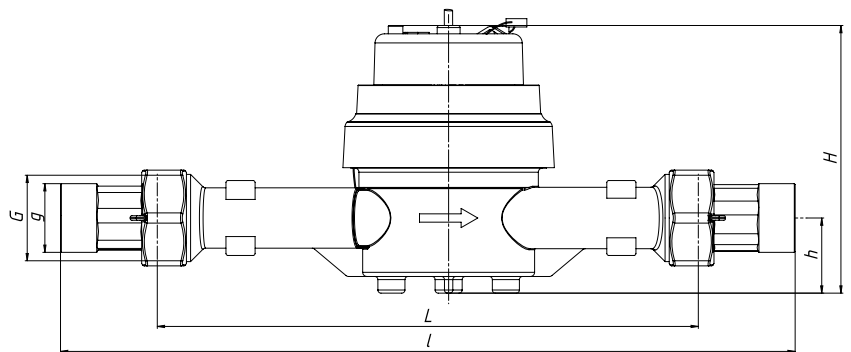

DN	JS NK	
L	mm	260
h	mm	36.1
H	mm	128.6

### Pressure loss chart

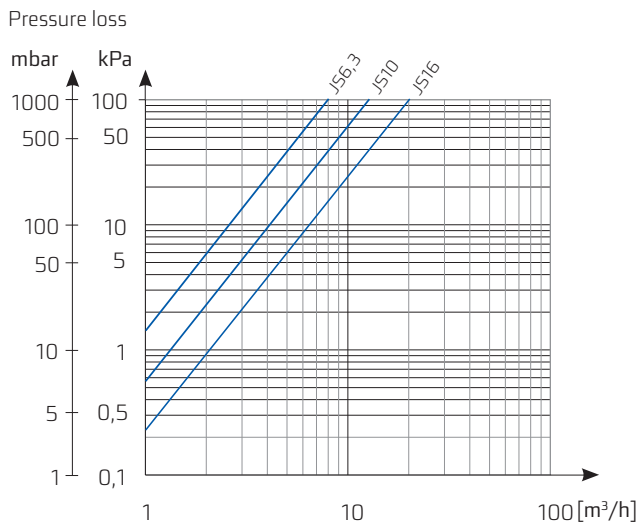

### Typical error chart

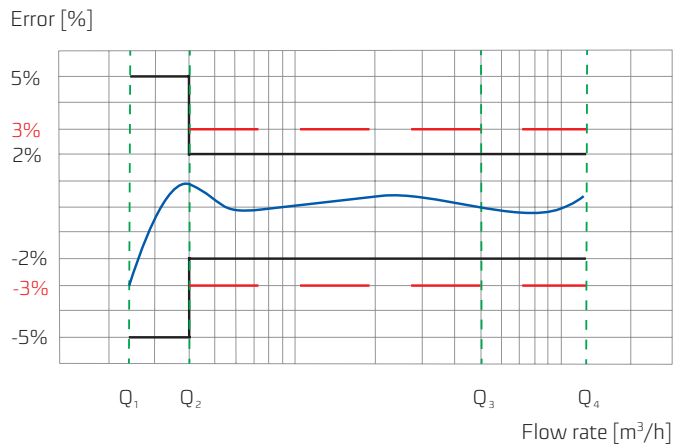

### Remote indication relay & flow rate measurement for IP68/IP65; flow rate measurement

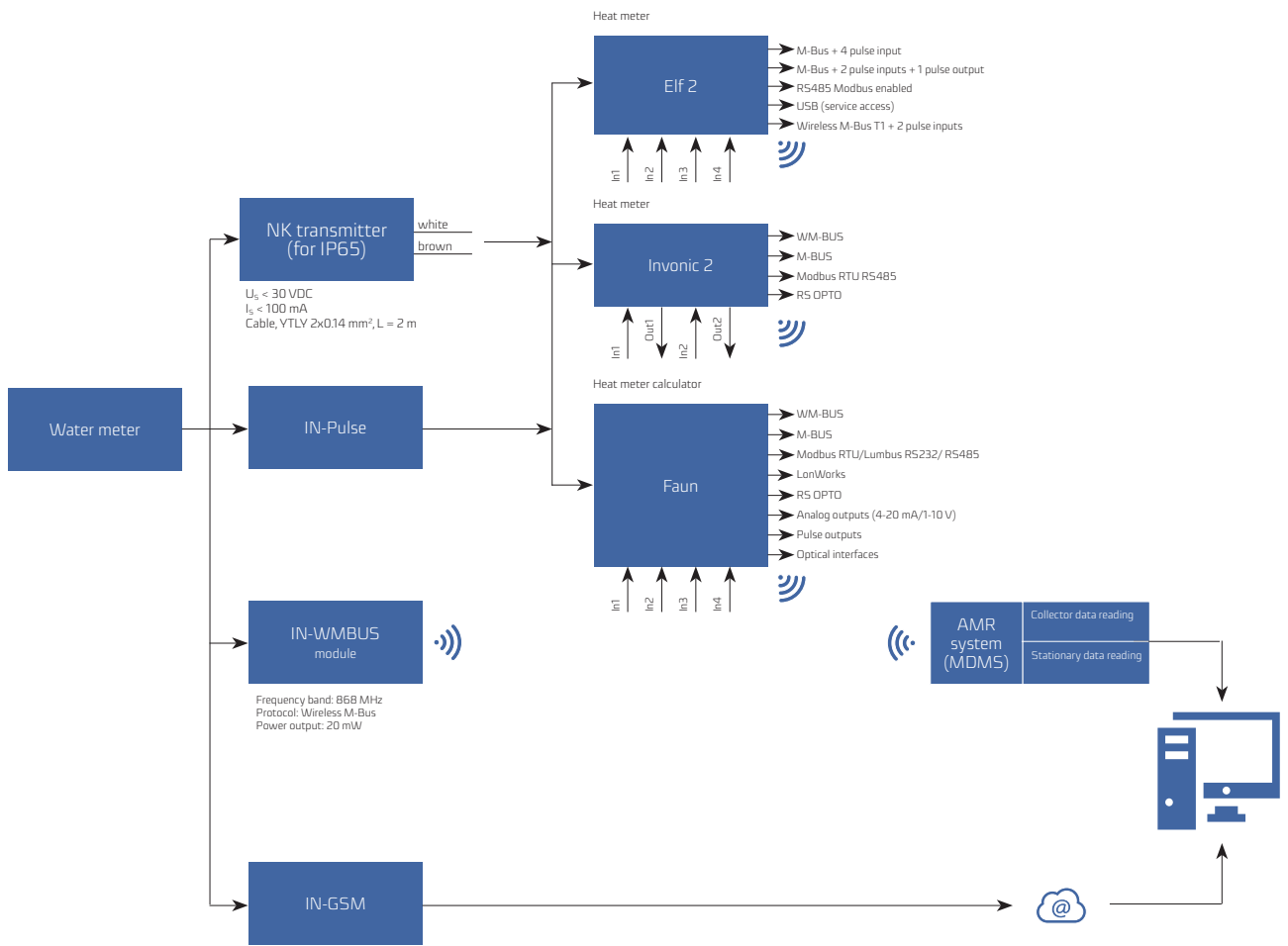

\* for IP65

The data shown here is current on the date of issue.  
The manufacturer has the right to modify and improve the products without notice.  
This publication is indicative only and should not be construed as a commercial offer under the Polish Civil Code.



**Apator Powogaz S.A.**

Jaryszki 1c, 62-023 Żerniki, Poland

**Office:** sekretariat.powogaz@apator.com, tel. +48 61 84 18 101

**Sales / Customer Service:** tel.: +48 61 84 18 149

**Customer Service Centre Support:** handel.powogaz@apator.com

**Export:** export.powogaz@apator.com

**Technical Support:** support.powogaz@apator.com, tel. +48 61 8418 131, 134, 294

**Warranty Claims:** reklamacje.powogaz@apator.com